



IMPORTANT FOR FUTURE REFERENCE	
Please complete this information and retain this manual for the life of the equipment:	
Model #:	_____
Serial #:	_____
Date Purchased:	_____

Installation & Operation Manual

Gas Kettles KSLG-20E, KSLG-40E, KSLG-60E, KSLG-80E, and KSLG-100E



Model KSLG-60E

WARNING

Improper installation, adjustment, alteration, service or maintenance can cause property damage, injury or death. Read the installation, operating and maintenance instructions thoroughly before installing or servicing this equipment.

SOUTHBEND STEAM

 **MIDDLEBY** A Middleby Company

1100 Old Honeycutt Road Fuquay-Varina, North Carolina 27526 USA

www.southbendnc.com



SAFETY PRECAUTIONS

Before installing and operating this equipment, be sure everyone involved in its operation is fully trained and aware of precautions. Accidents and problems can be caused by failure to follow fundamental rules and precautions.

The following symbols, found throughout this manual, alert you to potentially dangerous conditions to the operator, service personnel, or to the equipment.



This symbol warns of immediate hazards that will result in severe injury or death.



This symbol refers to a potential hazard or unsafe practice that could result in injury or death.



This symbol refers to a potential hazard or unsafe practice that could result in injury, product damage, or property damage.



This symbol refers to information that needs special attention or must be fully understood, even though not dangerous.

IMPORTANT NOTES FOR INSTALLATION AND OPERATION

WARNING

This is the safety alert symbol. It is used to alert you to potential personal injury hazards. Obey all safety messages that follow this symbol to avoid possible injury or death.

WARNING

FOR YOUR SAFETY:

Do not store or use gasoline or other flammable vapors or liquids in the vicinity of this or any other appliance.

WARNING

Improper installation, operation, adjustment, alteration, service or maintenance can cause property damage, injury or death. Read the installation, operating and maintenance instructions thoroughly before installing, operating or servicing this equipment.

NOTICE

This product is intended for commercial use only. NOT FOR HOUSEHOLD USE.

NOTICE

This manual should be retained for future reference.

PURCHASER: Instructions to be followed in the event the operator of this appliance smells gas must be posted in a prominent location. This information shall be obtained by consulting the local gas supplier.

DO NOT attempt to operate this unit in the event of a power failure.

Keep the appliance area free and clear from combustibles.

DO NOT obstruct the flow of combustion and ventilation air.

Adequate clearances **MUST** be maintained for servicing and proper operation.

Contact the factory, the factory representative or a local service company to perform maintenance and repairs should the appliance malfunction. Refer to warranty terms.

RETAIN THIS MANUAL FOR FUTURE REFERENCE.

Table of Contents

Important Notes For Installation and Operation	2
Service Connections	4
Installation	6
Performance Check	9
Operation	10
Maintenance	13
Service	17
Troubleshooting	21
Appendix A, Material Safety Data Sheet.....	22

SERVICE CONNECTIONS

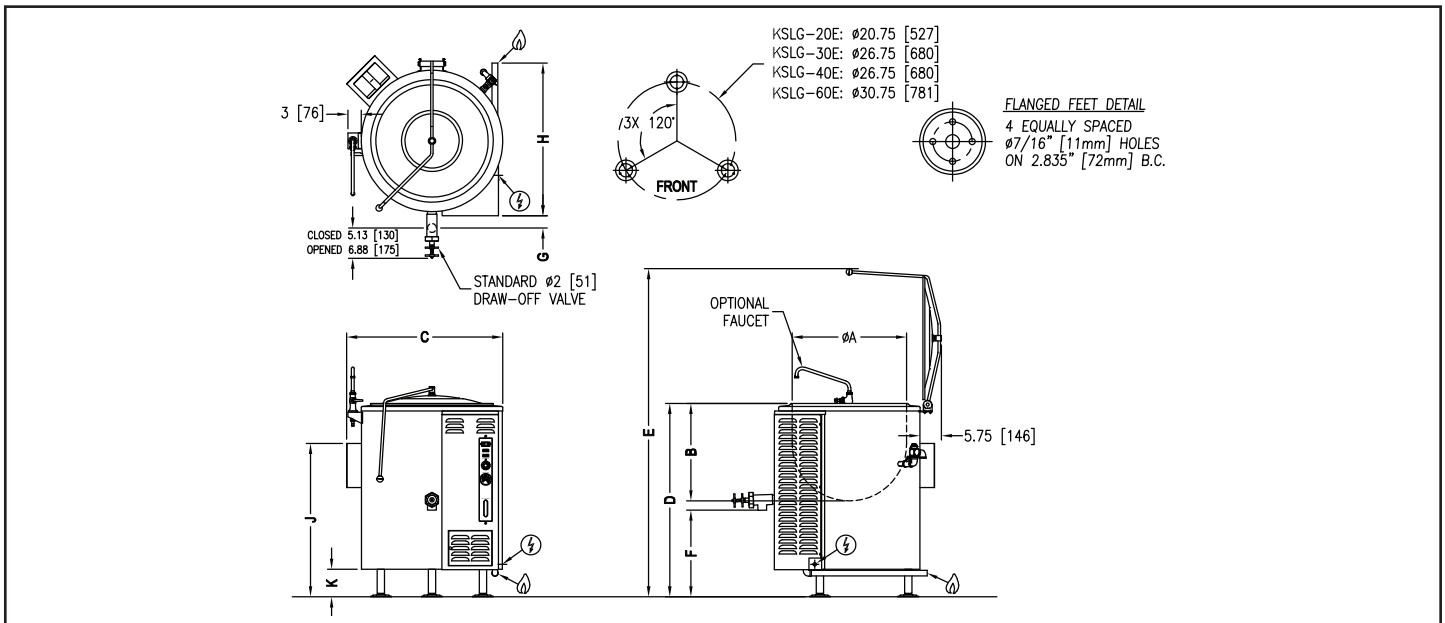

SERVICE CONNECTIONS

- Supply gas through 3/4" pipe. A gas shut-off valve must be installed in supply piping convenient and adjacent to appliance
- Unless other wise specified, Field Wire Electrical Connection to be 120 Volts, 60 Hertz, single phase with grounding wire. Unit furnished with 6' cord and 3 prong plug. Total maximum amps 4.0.

DIMENSIONS

MODEL	CAPACITY	UNITS	A	B	C	D	E	F	G	H	J	K
KSLG-20E	20 gallons (76 liters)	in (mm)	20" (508)	18.38" (467)	31.13" (791)	40.38" (1026)	65.38" (1661)	20" (508)	3.13" (79)	24.75" (629)	31.5" (800)	6.00" (153)
KSLG-30E	30 gallons (114 liters)	in (mm)	26" (660)	17.75" (451)	35.5" (902)	39.5" (1003)	69.75" (1772)	19.75" (502)	2.75" (70)	34.63" (879)	34.88" (886)	6.00" (153)
KSLG-40E	40 gallons (152 liters)	in (mm)	26" (660)	22.13" (562)	35.5" (902)	43.88" (978)	74.63" (1895)	19.75" (502)	2.75" (70)	34.63" (879)	34.88" (886)	6.00" (153)
KSLG-60E	60 gallons (227 liters)	in (mm)	30" (762)	24.75" (629)	39.75" (1010)	47.38" (1203)	84.5" (2146)	20.5" (521)	2.75" (70)	34.63" (879)	36.38" (924)	6.00" (153)

GAS CHARACTERISTICS

MODEL	GAS SUPPLY		
	BTU/HR.	kW/HR.	SUPPLY PIPE PRESSURE (W.C.)
KSLG-20/30/40E	100,000	29.3	Natural 6"-14" (152-356 mm) Propane 11"-14" (279-356 mm)
KSLG-60E	130,000	38.1	

* For use on non-combustible floors only.

SPECIFICATIONS

MODEL	SHIPPING WEIGHT	MINIMUM CLEARANCE	
KSLG-20E	440 lbs. [200 kg]	SIDES BACK	6" [152 mm] 2" [51 mm]
KSLG-30E	575 lbs. [261 kg]		
KSLG-40E	600 lbs. [272 kg]		
KSLG-60E	720 lbs. [327 kg]		

MODEL	CAPACITY	
KSLG-20E	20 Gallon	76 Liter
KSLG-30E	30 Gallon	114 Liter
KSLG-40E	40 Gallon	152 Liter
KSLG-60E	60 Gallon	227 Liter

As continued product improvement is a policy of Southbend Steam, specifications are subject to change without notice.

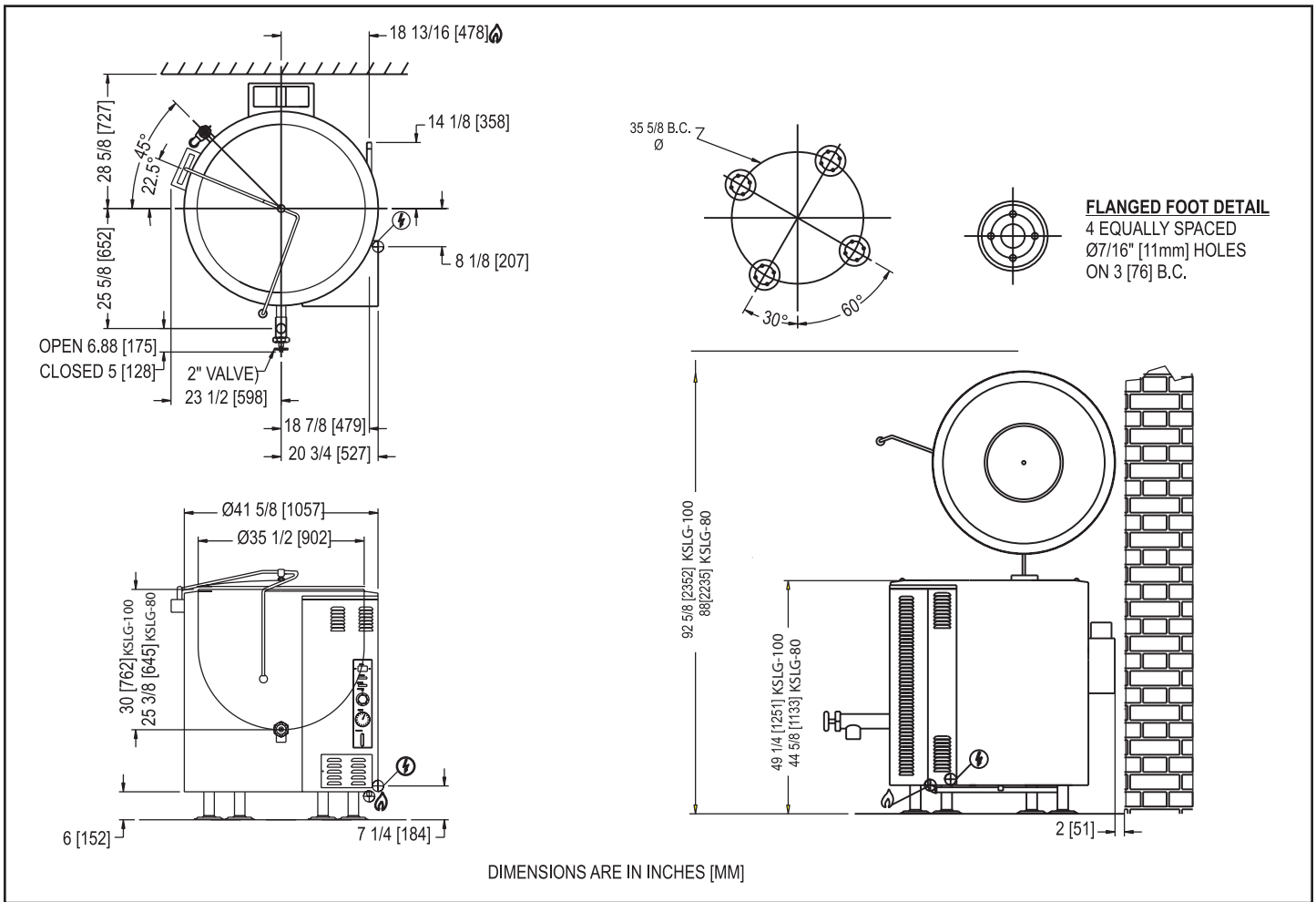

SERVICE CONNECTIONS

- 🔥 – Supply gas through 3/4" pipe. A gas shut-off valve must be installed in supply piping convenient and adjacent to appliance
- ⚡ – Unless other wise specified, Field Wire Electrical Connection to be 120 Volts, 60 Hertz, single phase with grounding wire. Unit furnished with 6' cord and 3 prong plug. Total maximum amps 2.0.

GAS CHARACTERISTICS

MODEL	GAS SUPPLY		
	BTU/HR.	kW/HR.	SUPPLY PIPE PRESSURE (W.C.)
KSLG-80E	150,000	44.0	Natural 6"-14" (152-355 mm)
KSLG-100E	150,000	44.0	Propane 11"-14" (279-355 mm)

* For use on non-combustible floors only.

SPECIFICATIONS

MODEL	CAPACITY	
KSLG-80E	80 Gallon	303 Liter
KSLG-100E	100 Gallon	379 Liter

MODEL	SHIPPING WEIGHT	MINIMUM CLEARANCE *	
KSLG-80E	950 lbs. [430 kg]	Side	6" [152 mm]
KSLG-100E	1100 lbs. [498 kg]	Back	2" [51 mm]

As continued product improvement is a policy of Southbend Steam, specifications are subject to change without notice.

INSTALLATION

UNPACKING

IMMEDIATELY INSPECT FOR SHIPPING DAMAGE

Immediately after unpacking the steamer, check for possible shipping damage. If the steamer is found to be damaged, save the packaging material and contact the carrier within 15 days of delivery.

Prior to installation, verify that the type of gas supply (natural or propane) and electrical service agree with the specifications on the rating plate located on the left side panel as you face the front of the braising pan. If the supply and equipment requirements do not agree, contact your dealer immediately.

INSTALLATION CODES AND STANDARDS

Installation must conform with local codes, or in the absence of local codes, with the National Fuel Gas Code, ANSI Z223.1/NFPA 54, or the Natural Gas and Propane Installation Code, CSA B149.1, as applicable.

1. The appliance and its individual shut off valve must be disconnected from the gas supply piping system during any pressure testing of that system at pressures in excess of 1/2 psi (3.5 kPa).
2. The appliance must be isolated from the gas supply piping system by closing its individual manual shut off valve during any pressure testing of the gas supply piping system at test pressures equal to or less than 1/2 psi (3.5 kPa).

Electrical grounding must be provided in accordance with local codes, or in the absence of local codes, with the National Electrical Code, ANSI/NFPA 70, or the Canadian Electrical Code, CSA C22.2, as applicable.

The electrical diagram is located on the inside of the console control cover

EXHAUST FANS AND CANOPIES: Canopies are set over ranges, ovens and kettles for ventilation purposes. It is recommended that a canopy extend 6” past appliance and be located 7.5 feet from the floor. Filters should be installed at an angle of 45 degrees or more with the horizontal. This position prevents dripping of grease and facilitates collecting the run-off grease in a drip pan, usually installed with the filter. A strong exhaust fan tends to create a vacuum in the room and may interfere with burner performance or may extinguish pilot flames. Makeup air openings approximately equal to the fan area will relieve such vacuum. In case of unsatisfactory performance on any appliance, check operation with exhaust fan in the “OFF” position.

WALL EXHAUST FAN: The exhaust fan should be installed at least 2 feet above the vent opening at the top of the unit.

CLEARANCES: Adequate clearance must be provided in aisle and at the side and back. Adequate clearances for air openings into the combustion chamber must be provided, as well as for serviceability.

SIDES	6 INCHES
BACK	2 INCHES AT FLUE BOX
FLOORS	6 INCH LEGS OR 8 INCH LEGS

All units must be installed in such a manner that the flow of combustion and ventilation air are not obstructed. Provisions for an adequate air supply must also be provided. Do not obstruct the lower front or right side of the unit, as combustion air enters through these areas. The bottom of the control area must also remain unobstructed.

TO INSTALL

1. Uncrate carefully. Report any hidden freight damage to the freight company immediately.
2. Set the unit in place. Be certain to maintain minimum clearances as stated above.
3. To level the unit use a spirit level in all directions on the top of the kettle (lid up).
 1. Units with legs - adjust the bottom foot on each leg to overcome an uneven floor.
 2. Units with casters - loosen the locking nuts, turn casters in or out as required and tighten locking nuts.
4. Be certain to leave adequate clearances for cleaning, maintenance and service.
5. The pressure relief valve is located at the left rear of the unit. This area should be kept clear and should not be in an area where operators will normally stand. The elbow on the relief valve should be turned toward the floor. A maximum 3 foot, 3/4" diameter pipe may be used to extend to the floor, but must not be piped directly to a drain. It must vent to the atmosphere.
6. Check the pressure gauge on the front panel before operating. If the pressure gauge does not indicate green vacuum zone (below 0 psi), see "Re-establishing Vacuum" section under SERVICE, after completing installation instructions.

GAS CONNECTION

The serial plate on the lower right side of the unit indicates the type of gas your unit is equipped to burn. Do NOT connect to any other gas type.

A 1" NPT line is provided at the rear for the connection. Each unit is equipped with an internal pressure regulator which is set for 4" W.C. manifold pressure for natural gas and 10" W.C. for propane gas. Use 1/8" pipe tap on the burner manifold for checking pressure.

An adequate gas supply is imperative. Undersized or low pressure lines will restrict the volume of gas required for satisfactory performance. A steady pressure, minimum 6" W.C. for natural gas and minimum 11" W.C. for propane gas, is recommended. With all units operating simultaneously, the manifold pressure on all units should not show any appreciable drop. Fluctuations of more than 25% on natural gas, and 10% on propane gas, will create pilot problems and affect burner operating characteristics. Contact your gas company for correct supply line sizes.

Purge the supply line to clean out any dust, dirt, or other foreign matter before connecting the line to the unit. It is recommended that an individual manual shut off valve be installed in the gas supply line to the unit. Use pipe joint compound which is suitable for use with LP gas on all threaded connections. Test pipe connections thoroughly for gas leaks.

WARNING

All connections must be checked for leaks, after the unit has been put in operation. Use soapy water only for testing on all gases. Never use an open flame to check for gas leaks.

NOTICE

If applicable, the vent line from the gas appliance pressure regulator shall be installed to the outdoors in accordance with local codes or, in the absence of local codes, with the *National Fuel Gas Code, ANSI Z223.1/NFPA 54, or the Natural Gas and Propane Installation Code CSA B149.1*, as applicable.

NOTICE

If this equipment is being installed at over 2,000 feet altitude and was not so specified on order, contact service department. Failure to install with proper orifice sizing may void the warranty.

WATER CONNECTION

On units equipped with an optional water fill valve connect a water line (minimum 1/4") to the valve with a 1/4" NPT female fitting. Units with dual (hot and cold) valves must have the hot water line connected to side with the hot water valve (red) and cold water line to the cold water valve (blue). Plastic or rubber hose is not recommended, as it may melt against the hot kettle side.

WARNING

For an appliance equipped with casters, the installation shall be made with a connector that complies with the standard for connectors for moveable gas appliances, ANSI Z21.69-CSA 6.16 and a quick-disconnect device that complies with the standard for quick-disconnect devices for use with gas fuel, ANSI Z21.41-CSA 6.9; adequate means must be provided to limit the movement of the appliance without depending on the connector and the quick disconnect device or its associated piping to limit the appliance movement; the location where the restraining means may be attached to the appliance is on bottom of unit directly below relief valve.

If the unit is also equipped with an optional water fill valve it too must be installed with a flexible water supply tube, a quick disconnect and strain relief.

ELECTRICAL CONNECTION

WARNING

In the event of main burner ignition failure, a 5 minute purge period must be observed prior to re-establishing ignition source.

WARNING

ELECTRICAL GROUNDING INSTRUCTIONS

This appliance is equipped with a three-prong (grounding) plug for your protection against shock hazard and should be plugged directly into a properly grounded three-prong receptacle. Do not cut or remove the grounding prong from this plug. (120V units only).

1. 120 VAC - 60 Hz - Single Phase

Units with this electrical rating are factory supplied with a three-wire cord and three-prong plug which fits any standard 120V, three-prong grounded receptacle. A separate 15 amp supply is needed for each unit.

2. 208/240 VAC - 60 Hz - Single and Three Phase

Units with this electrical rating are factory equipped with a transformer. To connect supply wires remove cover from transformer box at right rear of unit. Route supply wires and ground wire through the hole in the cover with a strain relief fitting. Connect wires to the primary transformer terminals as required by your power supply voltage. Connect ground wire to ground lug. Replace cover. Three-phase units are wired as above, using only two supply wires. The third supply wire is not connected and must be properly terminated.

3. 220 VAC - 50 Hz - Single Phase

Units equipped with this voltage rating should be wired exactly as in (Step 2) above.

PERFORMANCE CHECK

The following items should be checked before or within the first 30 days of operation by a qualified service technician.

1. Verify correct gas type.
2. Verify correct voltage, cycle and phase.
3. Gas pressure.
4. Internal gas connections.
5. Internal electrical connections.
6. Pilots - adjustment and ignition.
7. Burners - adjustment and ignition.
8. Thermostat - cycle for operation check.
9. Supply valve - check for operation.
10. Check hinge and lid assembly.
11. Draw-off valve - check operation.
12. Advise user on cleaning procedures.

OPERATION

NOTICE

Contact the factory, the factory representative or a local service company to perform maintenance and repairs should the appliance malfunction.

WARNING

In the event of main burner ignition failure, a 5 minute purge period must be observed prior to re-establishing ignition source.

WARNING

In the event you smell gas, shut down equipment at the main shut off valve and contact the local gas company or gas supplier for service.

CAUTION

If you smell gas during the lighting procedure, immediately shut off the gas supply until the leak has been corrected.

GAS CONTROL INSTRUCTIONS

Appliance does not require “Lighting” the pilot with a flame.

A. START-UP

1. Turn thermostat to “OFF” position and power switch to “OFF” position.
2. Open control panel access door located on right side at bottom.
3. Turn dial on combination control to “ON” position by rotating control knob counterclockwise. (NOTE: Any gas service valves exterior to the unit should be open.)
4. Turn “POWER” switch to “ON” position.
5. Set “COOK TEMP” to desired setting. The red “COOKING” pilot will be on until desired setting has been reached.
6. At this time the spark igniter will begin sparking at the pilot until the pilot is ignited, or for ninety seconds (an audible clicking sound will be evident).
7. When the pilot is ignited the spark igniter will automatically stop and within 15 seconds main burner gas will come on. If ignition does not occur, after a total of ninety seconds, the unit will lockout, shutting off all gas although the spark igniter will continue to spark. New installations (where there may be a considerable amount of air in the gas line) may require the unit to be turned off and immediately back on numerous times after each lockout period until the air is purged from the gas line.

B. SHUTDOWN

1. STANDBY

1. Place power on switch and thermostat to “OFF” position.

2. COMPLETE

1. Place power on switch and thermostat to “OFF” position.
2. Turn dial on combination control from “ON” position to “OFF” position.
3. Turn any main gas service valves supplying gas to “OFF” position.

C. RE-LIGHTING

1. Turn power switch to “ON” position.

It should be noted that the pilot and electronic ignition do not cycle with the thermostat. A standing pilot is automatically established and monitored each time the power switch is turned ON. If the pilot is ever extinguished by a momentary external interruption, the spark igniter will automatically relight it without disturbing the cooking cycle, unless lockout occurs.

SPARK IGNITER FAILURE

In the event the spark igniter module fails the unit may still be operated by carefully following these instructions.

1. Turn thermostat to OFF position; completely counterclockwise.
2. Turn power switch to OFF position.
3. WAIT A MINIMUM OF 5 MINUTES BEFORE PROCEEDING.
4. Turn dial on combination control to ON position (if not already on).
5. Turn power switch to ON position.
6. Wait two minutes and ten seconds and then immediately light pilot with long match or taper.
7. After 10 - 15 seconds gas valve will allow main burner gas to flow when thermostat is turned on.
8. The pilot will now stay ignited as long as the power switch remains ON. If power switch is turned OFF, repeat the above instructions. It is intended that the unit be operated in this manner only in emergency situations and only while it is attended (do not leave pilot lit overnight; shut off power switch). A qualified serviceman must be called promptly.

FRONT PANEL CONTROLS

POWER SWITCH: This switch turns the main power to the unit on and off. It must be turned on to heat the kettle. It should be turned off when the kettle will not be in use for long periods.

COOKING LIGHT (RED): This light is on whenever the main burner gas is on. On units with standing pilots this light may be on without the burners being on if the pilot is extinguished. See lighting instructions.

LOW WATER LIGHT (AMBER): .. All kettles are supplied with sufficient distilled water in the pressurized jacket. If at any time the water level falls below that required for proper operation, the kettle will not heat and this light will come on. See “Adding Water” section of service instructions.

THERMOSTAT: The thermostat selects the desired internal kettle operating temperature. The thermostat must be set at a desired setting in order for the burner to ignite. Reference Dial Setting table below.

PRESSURE GAUGE:..... The pressure gauge indicates the internal operating pressure of the kettle. When cold, the gauge should be in the green vacuum zone. If it is not, refer to “Re-establishing Vacuum” section of service instructions. Under normal operation with the kettle empty (thermostat set at 275 degrees Fahrenheit) the pressure shall reach 30 psi. When loaded the pressure may be considerably less.

SIGHT GLASS: The sight glass indicates the minimum and maximum water level within the kettle. If water level falls below minimum level more distilled water should be added. See “Adding Water” section of service instructions.

PRESSURE RELIEF VALVE: The pressure relief valve is a safety device which prevents the internal kettle pressure

from ever exceeding 50 psi. It should never be tampered with.

DAILY OPERATION

Daily operation should consist of turning on the power switch and setting the thermostat for the desired temperature.

It is recommended the kettle be preheated prior to use. Milk or egg based products should be placed in the kettle before heating, however, to prevent sticking. The kettle is preheated when the cooking light goes off the first time.

At the end of each day, or if the kettle will not be used for some time, shut the unit down by turning the power switch to OFF.

Clean as required or on a daily basis. See "Cleaning" section under MAINTENANCE.

Appliances equipped with casters have been installed with a restraint to limit their movement to prevent damage to the gas supply connecting system. If disconnection of this restraint is necessary to move the appliance for cleaning, etc., reconnect it when the appliance is moved to its originally installed position.

Turning on the power switch initiates a pilot lighting sequence. The spark igniter will begin sparking. The spark igniter will spark until the pilot is ignited. After ninety seconds lockout will occur. Lockout shuts down all pilot (and main burner) gas flow although the spark igniter will continue to spark. The power switch must be turned off and back on to restart the pilot lighting sequence once lockout has occurred.

If the pilot blows out during operation, the unit will go through the same sequence to re-ignite itself.

Once the pilot is ignited, main burner gas will flow if the thermostat is turned on.

END USE TIPS

For easier cleaning add cold water to the kettle immediately after removing contents.

When preparing foods containing vinegar or tomatoes, or those which have a high salt content, clean the kettle immediately after using to prevent pitting.

Do not use salt to clean the kettle. This will scratch the surface.

If using saltwater to cook shellfish, be sure to rinse and wash the kettle thoroughly.

Bring milk and egg products slowly up to temperature in a cold kettle to prevent product adhering to the sides.

When planning actual cooking capacity, allow room at top for stirring without spilling.

When preparing puddings from a mix, place the powder in a cold kettle, add a small amount of the liquid, and stir to form a thin paste. Turn on the kettle and add the remainder of the liquid. Continue as per recipe instructions.

When browning meat bring the kettle up to temperature before adding. This seals in the juices in the meat.

VENT SYSTEM

At least twice a year the unit venting system should be examined and cleaned.

GAS SAVING TIPS

Use these reminders to help develop energy-saving procedures and habits. Using less natural or propane gas saves energy as well as money.

1. Turn off when not in use.
2. Limit preheat times.
3. Use lid when possible.
4. Maintain equipment.

MAINTENANCE

NOTICE

Contact the factory, the factory representative or a local service company to perform maintenance and repairs.

WARNING

Disconnect the power supply to the appliance before cleaning or servicing.

DAILY

1. Wash exposed cleanable areas.

MONTHLY

1. Clean around burner air mixers, louvered panels and pilots if grease or lint have accumulated.

TWICE A YEAR (MINIMUM)

Have an authorized service person clean and adjust the unit for maximum performance.

It is **NOT RECOMMENDED** to use cleaning agents that are corrosive.

Use of cleaning agents that contain chloride, acids or salts are corrosive and may cause pitting and corrosion when used over a period of time; this will reduce life of the appliance.

Should pitting or corrosion occur this is not covered by warranty.

Follow the recommended cleaning instructions. Use a mild detergent, warm water and rinse thoroughly.

Never spray water into electric controls.

NOTICE

Draw-off valve has a vulcanized rubber coated stem for better sealing. Do not over tighten. This may cause the rubber to pull away from stem and permanently damage it. This is not covered under warranty.

CLEANING INSTRUCTIONS

WARNING

Disconnect the power supply to the appliance before cleaning or servicing.

WARNING

Never spray water into electric controls or components!

WARNING

The equipment and its parts are hot. Use care when operating, cleaning and servicing.

CAUTION

Do not use cleaning agents that are corrosive.

Your kettle should be cleaned immediately after each use or when cooking a different product. Before cleaning, check that the kettle has cooled enough to touch it.

1. Rinse the inside of the kettle thoroughly and drain to remove any food particles.
2. Using a nylon brush, clean the kettle with a mild detergent and water. Never use steel wool or scouring powder as it will scratch stainless steel. Plain steel wool can leave small pieces of steel which can rust.
3. Rinse the inside of the kettle thoroughly with clean water. Drain the kettle by tilting or through the tangent draw-off valve, depending on model, to allow the detergent and water solution to drain.
4. Wipe the exterior of the kettle with a clean, damp cloth.

WARNING

If you are cleaning a valve that is assembled to a kettle, be sure the kettle is **completely empty of any product**.

DRAW-OFF VALVE CLEANING

NOTICE

Draw-off valve has a vulcanized rubber coated stem for better sealing. Do not over tighten. This may cause the rubber to pull away from stem and permanently damage it. This is not covered under warranty.

1. If equipped with a tangent draw-off valve, turn the large hex nut on the draw-off valve counterclockwise until it is completely disengaged from the threads. Grasp the valve knob and slowly pull out the valve stem and disk. Do not allow the disk to come in contact with hard surfaces as it can be damaged and cause valve leakage. Wash the valve stem, disk and handle. Insert a nylon brush, wet with detergent and water, into the valve body and tangent draw-off tube. Brush vigorously.
2. Replace the valve stem assembly and turn the hex nut until snug. Rinse the kettle with clean warm water.
3. Leave the draw-off valve open when the kettle is not in use.

DAIRY DRAW-OFF VALVE CLEANING

1. Remove the plug by first removing the handle, then turn the plug to line up with the pin and pull with both hands. It is important to use both hands because the plug is heavy.
2. Put the plug in a plastic pail that contains a mild soap solution. A plastic pail works best, as it reduces the possibility of nicking or scratching the plug. If the plug gets scratched it may not seal correctly and could leak.
3. Use a soft cloth or soft brush and clean all surfaces.
4. Using both hands remove the valve from the soap and rinse well in another plastic pail that contains fresh water.
5. Wash out the kettle as normal.
6. Once the kettle is washed out, return the plug into the body. Be sure the plug is inserted into the notch and turned. Ensure the plug is tight and secure before letting go of it.

If you are cleaning a body and plug assembly, remove the plug and follow the above procedures. When finished with the plug, follow the same instructions for washing the body. Always use both hands when handling the plugs. Re-assemble the plug into the body and use as normal.

WHAT TO DO IF SURFACE RUST APPEARS

Metal utensils should never be used as they will scratch the surface of the equipment and rust may begin to form. To remove surface accumulation of rust from the inadvertent use of such utensils, the following procedure may be used.



Improper use of this procedure may damage your appliance!

1. Use undiluted white vinegar with a non-abrasive scouring pad (plastic) or cloth on the affected area to remove the rust stain. The appliance should not be heated and remain at room temperature during the entire cleaning process.
2. If the stain resists removal, additional exposure time with vinegar may be required, to a maximum of one hour.
3. Thoroughly wash all of the vinegar away with fresh clear water. Dry the surface completely and allow one hour before using the appliance to cook.

Following daily and period maintenance procedures will prolong the life for your equipment. Climatic conditions - salt air - may require more thorough and frequent cleaning or the life of the equipment could be adversely affected.

STAINLESS STEEL

To remove normal dirt, grease or product residue from stainless steel, use ordinary soap and water (with or without detergent) applied with a sponge or cloth. Dry thoroughly with a clean cloth. Never use vinegar or any other corrosive cleaner.

To remove grease and food splatters or condensed vapours that have baked on the equipment, apply cleanser to a damp cloth or sponge and rub cleanser on the metal in the direction of the polishing lines. Rubbing cleanser as gently as possible in the direction of the polished lines will not mar the finish of the stainless steel. **NEVER RUB WITH A CIRCULAR MOTION.**

Soil and burn deposits which do not respond to the above procedure can usually be removed by rubbing the surface with **SCOTCH-BRITE™** scouring pads or **STAINLESS** scouring pads. **DO NOT USE ORDINARY STEEL WOOL** as any particles left on the surface will rust and further spoil the appearance of the finish. **NEVER USE A WIRE BRUSH, STEEL SCOURING PADS (EXCEPT STAINLESS), SCRAPER, FILE OR OTHER STEEL TOOLS.** Surfaces which are marred collect dirt more rapidly and become more difficult to clean. Marring also increases the possibility of corrosive attack. Refinishing may then be required.

TO REMOVE HEAT TINT: Darkened areas sometimes appear on stainless steel surfaces where the area has been subjected to excessive heat. These darkened areas are caused by thickening of the protective surface of the stainless steel and is not harmful. Heat tint can normally be removed by the foregoing, but tint which does not respond to this procedure calls for a vigorous scouring in the direction of the polish lines using **SCOTCH-BRITE™** scouring pads or a **STAINLESS** scouring pad in combination with a powdered cleanser. Heat tint action may be lessened by not applying or by reducing heat to equipment during slack periods.

All food contact surfaces must be thoroughly drained and flushed prior to cooking in the kettle

CONTROL PANEL: The textured control panel should be cleaned with warm water and mild soap. Never use an abrasive cloth or steel wool. Never use cleaning solvents with a hydrocarbon base.

SAFETY VALVE MAINTENANCE AND TESTING

CAUTION

Under normal operating conditions a “try lever test” should be performed every two months. Under severe service conditions, or if corrosion and/or deposits are noticed within the valve body, testing must be performed more often. A “try lever test” should also be performed at the end of any non-service period.

CAUTION

Hot, high pressure fluid may be discharged from body drain and vent during “try lever” test. Care must be taken to avoid any bodily contact.

CAUTION

High sound levels may be experienced during “try lever” test.

Wear proper safety equipment and exercise extreme care!

Test at, or near, half of the operating pressure by holding the test lever fully open for at least two seconds to flush the valve seat free of sediment and debris. Then release lever and allow the valve to snap shut.

If lift lever does not activate, or there is no evidence of discharge, turn off equipment immediately and contact a licensed contractor or qualified service personnel.

SERVICE

! WARNING

Disconnect the power supply to the appliance before cleaning or servicing.

GENERAL

When any difficulty arises always check that the unit has been connected to the gas supply type and voltage for which it was supplied. This can be done by examining the serial plate on the lower right side of the unit. It will list the gas type and voltage for which the unit was manufactured.

Wiring diagrams for the unit are located in a small envelope affixed to the side panel of left hand console.

UNIT	TOTAL INPUT	ORIFICE SIZE	
		NATURAL	PROPANE
KSLG-20	100,000 BTU/Hour	30	45
KSLG-40	100,000 BTU/Hour	30	45
KSLG-60	130,000 BTU/Hour	23	39
KSLG-80E/KSLG-100E	150,000 BTU/Hour	30	45

MANIFOLD PRESSURE

Natural Gas - 4 inches W.C. **LP Gas** - 10 inches W.C.

PILOTS

The pilot adjustment is part of the combination control valve located just behind the lower front access door. It is located on the centre left side of the control just below the large slotted screw head. (See Figure 1). Remove the large slotted screw; below this is a second slotted screw used for adjustment of the pilot burner flame.

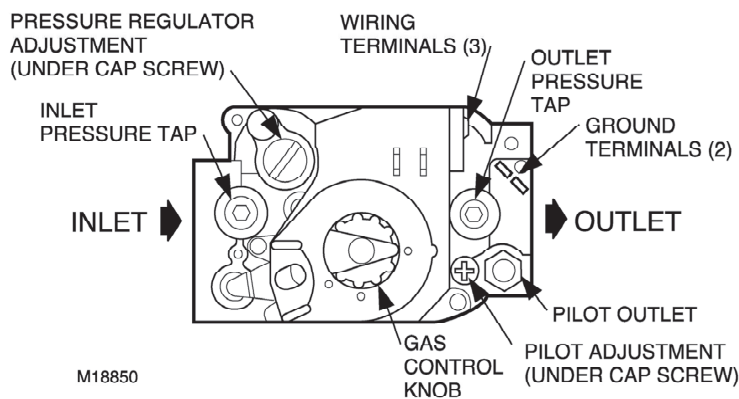

Figure 1. Top view of gas control

The front burner shield should be removed to see the pilot. The pilot should be adjusted as follows:

Adjust the pilot burner flame

The pilot flame should envelop 3/8 to 1/2 inch [10 to 13 mm] of the igniter-sensor tip. Refer to Figure 2. To adjust the pilot flame:

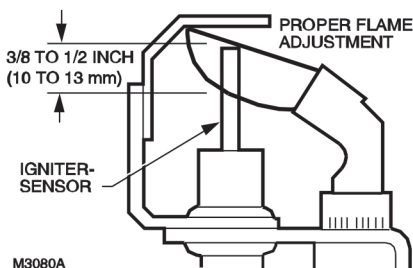

Figure 2. Proper flame adjustment

1. Remove the pilot adjustment cover screw. Refer to Figure 1.
2. Turn the inner adjustment screw clockwise to decrease or counterclockwise to increase the pilot flame.
3. Always replace the cover screw after adjustment and tighten firmly to ensure proper operation.

Pilot Orifices Sizes

NATURAL	PROPANE
0.018 IN.	0.010 IN.

GAS PRESSURE REGULATOR

The gas pressure regulator is an integral part of the combination gas control located just behind the lower front access door. The pressure regulator adjustment is on the lower right side of the gas control (see Figure 1). The large slotted cap must be removed to access the adjustment screw.

To check the manifold pressure a pressure gauge (manometer) must be connected to the 1/8" NPT pressure tap on the gas manifold. With the gas off, connect your pressure indicating instrument to the manifold with a fitting appropriate for your instrument.

1. Turn the unit on; with main burners on, read the manifold pressure. The pressure should be 4 inches water column (W.C.) (\pm) .2 inches W.C. for natural gas or 10 inches W.C. for propane gas. Adjust the pressure regulator to obtain the appropriate pressure. Check serial plate on lower right side of unit to confirm exact gas type and manifold pressure for your unit.

When pressure has been correctly adjusted turn unit off. Remove pressure indicating instrument and replace the 1/8" NPT plug in manifold. Replace regulator cap and close access door.

THERMOSTAT

The thermostat adjustment should not be changed. Check the following before changing the thermostat.

1. With kettle cool, the pressure reading on the pressure gauge should be in the green vacuum zone (below 0 psi). If not, see "Re-establishing Vacuum" section.
2. Check that the pressure switch is not set too high or too low and causing the out of adjustment condition. A voltmeter should be used by a properly trained serviceman to determine if the pressure switch or thermostat is actually cycling the burners. If the pressure switch is found to be the problem, see "Pressure Switch" section.

After verifying that the pressure switch is set and operating properly, the thermostat may be adjusted using the set screw inside the stem. The thermostat should cycle off at a gauge pressure reading of 30 psi. Turn set screw clockwise to decrease pressure and counterclockwise to increase pressure.

PRESSURE SWITCH

The pressure switch should not be adjusted until it is determined to be the cause of an operating pressure deficiency. See "Thermostat" section to determine if the source of difficulty is the pressure switch or thermostat.

The major difficulties caused by pressure switch mis-adjustment are:

1. Pressure relief valve opening, especially on preheat from a cold start to 275 degrees Fahrenheit (135°C) (pressure switch set too high).
2. Burners are being shut down by pressure switch, not the thermostat. (Pressure switch set too low.)

The pressure switch is preset for proper operation from the factory. It is adjusted to the maximum pressure, however not high enough to cause the pressure relief valve to open. This setting will be slightly different on different kettles due to variations in the pressure relief valves. During preheat to the maximum thermostat setting (275 degrees Fahrenheit) (135°C), from either a cold condition or a lower temperature setting, the temperature may overshoot the thermostat setting and shut down the burners by the pressure switch. This is normal, however, after the kettle cycles several times (empty) the thermostat will begin cycling the unit.

TO ADJUST PRESSURE SWITCH

1. To obtain access to the pressure switch, the front panel must be removed. Remove the screws on either side of the panel. Be sure to support the panel to avoid excessive strain on the wiring.
2. To increase the pressure setting turn the white ribbed knob clockwise; to decrease the pressure, turn it counterclockwise. Use the centre of the black ring as an indicator.
3. With the kettle empty and completely cold, bypass the thermostat by moving the single terminal side wire to the double terminal side connector on the thermostat. Turn kettle on.
4. Pressure in kettle (read pressure gauge on front panel) should reach a maximum of 35 psi and pressure relief valve should not open. Kettle pressure may rise 3 or 4 psi even after burners shut down.
5. Relief valve should not open when kettle pressure is 40 psi; pressure switch setting is satisfactory.
6. If relief valve opens, reduce setting on pressure switch, cool kettle completely by running cold water through it and repeat steps 3 - 6.
7. If pressure in kettle is below 30 psi when burners shut off, increase setting of pressure switch, cool kettle completely by running cold water through it and repeat steps 3 - 7.
8. When adjustment is complete, move wire from shorted terminal on the thermostat back to the appropriate terminal and replace the front panel.

ADDING WATER (LOW WATER LIGHT COMES ON)

It may be necessary to replenish water in the jacket when the low water indicator comes on. Do so as follows:

1. Unit should be completely cold and off.
2. Lift handle of pressure relief valve to release vacuum in kettle. (Relief valve is at right rear of kettle).
3. Remove air vent nut on the tee located between kettle and relief valve.
4. Using pure distilled water only, pour the water into the opening. (A funnel will be helpful). Water will enter the kettle slowly, as air must escape through the same hole. Water should be added until the water level at the sight glass is half way between the minimum and maximum levels.
5. When sufficient water has been added, replace and tighten the nut.
6. Vacuum must be re-established. (See Re-establishing Vacuum).

FOR REFERENCE:

The total amount of distilled water contained in each unit, and amount to be added in a low water condition is listed below:

MODEL	TOTAL AMOUNT OF DISTILLED WATER	AMOUNT OF WATER TO BE ADDED IN A LOW WATER CONDITION
GL - 20	4.8 Gallons	155 fluid ounces (4 L)
GL - 40	6.9 Gallons	236 fluid ounces (7 L)
GL - 60	9.5 Gallons	236 fluid ounces (7 L)
KSLG-80E/KSLG-100E	16.3 Gallons	721 fluid ounces (10 L)

RE-ESTABLISHING VACUUM

With the kettle completely cold a vacuum of 25 to 30 inches mercury column (M.C.) should be maintained as indicated in the green zone on the pressure gauge on the front control panel. If at any time the vacuum is not in the green zone, vacuum should be re-established.

With the kettle empty, turn the thermostat knob to the highest temperature. When the temperature pilot light goes off, open air vent nut one (1) full turn for 20 seconds and then close and tighten the nut. This should remove the air and any loss in performance should return.

Should the kettle fail to maintain a vacuum after repeated attempts to establish it, further checks should be made to see if the pressure relief valve is leaking or if there are any leaks in the pressure relief valve piping, copper lines going to the pressure switch, pressure gauge or thermostat fitting.

CONTROL CIRCUIT FUSES

The control circuit is protected by a 3 amp. fuse which is located inside control panel, top right side above transformer.

Should the unit fail to turn on, check this fuse by removing it and either replacing it or testing it with a continuity tester. If the fuse is good, check the main power circuit breaker, which should be external to the kettle.

CONVERTING BETWEEN NATURAL AND PROPANE GAS

Standard- or slow-opening gas controls may be converted from one gas to another. To convert from natural gas to LP use the 393691 LP Conversion Kit that is included with the VR8304M Gas Control. To convert from LP to natural gas use the 394588 Natural Gas Conversion Kit (order separately). Step-opening gas controls cannot be converted.

To convert control from one gas to another:

1. Turn off main gas supply to the appliance.
2. Remove the regulator cap screw and pressure regulator adjusting screw. See Figure 3.
3. Remove the existing spring.
4. Insert the replacement spring with tapered end down. See Figure 4.
5. Install the new plastic pressure regulator adjustment screw so that the top of the screw is flush (level) with the top of the regulator. Turn the pressure regulator adjustment screw clockwise six complete turns. This provides a preliminary pressure setting of about 10 inch (254 mm) W.C. for LP regulator and 4 inch (102 mm) W.C. for natural gas regulator.
6. Check the regulator setting either with a manometer or by locking the gas meter.
7. Install the new cap screw.
8. Mount conversion label on control.
9. Install control and appliance according to appliance manufacturer's instructions.

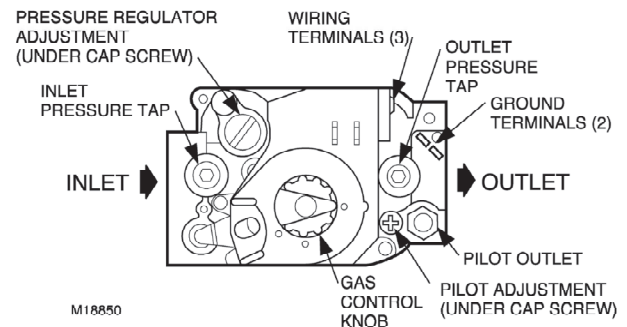

Figure 3. Top view of gas control

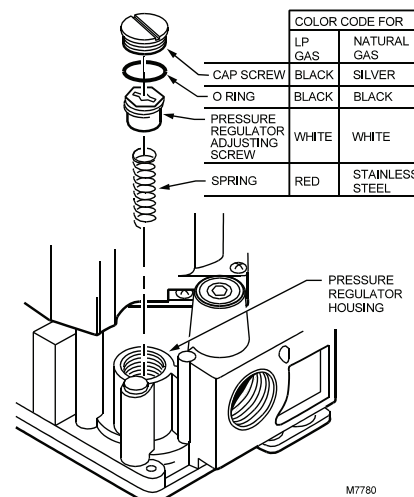

Figure 4. Installation of conversion kit in regulated gas control.

TROUBLESHOOTING

NOTICE

Loose, broken or grounded wiring may cause many of the symptoms listed.
Check all wiring and make sure it is intact.

PROBLEM	PROBABLE CAUSE
Unit will not come on.	Power switch is off.
	Unit not plugged in.
	Main power supply off.
	Bad electronic module.
	Bad low water control.
	Bad spark igniter.
	Bad intermittent pilot burner.
	Fuse in unit blown.
Unit will turn on electrically but will not heat.	Lockout has occurred.
	Thermostat not on.
	Gas control valve off.
	Main gas supply off.
	Low water.
	Bad thermostat.
	Bad pressure switch.
	Bad gas control valve.
	Bad spark igniter.
	Bad igniter cable.
	Bad intermittent pilot burner.
	Faulty gas control.
Excessive flame rollout on ignition, carboning.	Natural gas unit on propane.
	Excessive gas pressure.
	Incorrect orifice size.
	Faulty regulator in gas control.
Unit slow to preheat and slow to recover.	Propane gas on natural.
	Low gas pressure.
	Incorrect orifice sizes.
	Loss of vacuum.
	Faulty regulator in gas control.
Unit continuously locks out.	Pilot gas adjusted too low.
	Excessive draft condition.
	Excessive steam around bottom of unit during operation of cleaning.
	Faulty transformer.
	Faulty electronic module.
	Faulty ignitor cable.
	Faulty spark igniter.
	Faulty gas control.

APPENDIX 'A'

SAFETY DATA SHEET
 DOW CHEMICAL CANADA ULC

Product name: DOWFROST™ HD Heat Transfer Fluid, Dyed

Issue Date: 01/19/2017

Print Date: 01/23/2017

DOW CHEMICAL CANADA ULC encourages and expects you to read and understand the entire (M)SDS, as there is important information throughout the document. We expect you to follow the precautions identified in this document unless your use conditions would necessitate other appropriate methods or actions.

1. IDENTIFICATION

Product name: DOWFROST™ HD Heat Transfer Fluid, Dyed

Recommended use of the chemical and restrictions on use

Identified uses: Intended as a heat transfer fluid for closed-loop systems. We recommend that you use this product in a manner consistent with the listed use. If your intended use is not consistent with the stated use, please contact your sales or technical service representative.

COMPANY IDENTIFICATION

DOW CHEMICAL CANADA ULC
 #2400, 215 - 2ND STREET S.W.
 CALGARY AB T2P 1M4
 CANADA

Customer Information Number:

800-258-2436
 SDSQuestion@dow.com

EMERGENCY TELEPHONE NUMBER
24-Hour Emergency Contact: 1-888-226-8832

Local Emergency Contact: 613-996-6666

2. HAZARDS IDENTIFICATION

Hazard classification

This product is not hazardous under the criteria of the Hazardous Products Regulation (HPR) as implemented under the Workplace Hazardous Materials Information System (WHMIS 2015).

Other hazards

No data available

3. COMPOSITION/INFORMATION ON INGREDIENTS

This product is a mixture.

Component	CASRN	Concentration
-----------	-------	---------------

Propylene glycol	57-55-6	> 93.0 %
Water	7732-18-5	< 5.0 %
Dipotassium hydrogen phosphate	7758-11-4	< 5.0 %

4. FIRST AID MEASURES

Description of first aid measures

General advice: If potential for exposure exists refer to Section 8 for specific personal protective equipment.

Inhalation: Move person to fresh air; if effects occur, consult a physician.

Skin contact: Wash off with plenty of water.

Eye contact: Flush eyes thoroughly with water for several minutes. Remove contact lenses after the initial 1-2 minutes and continue flushing for several additional minutes. If effects occur, consult a physician, preferably an ophthalmologist.

Ingestion: No emergency medical treatment necessary.

Most important symptoms and effects, both acute and delayed: Aside from the information found under Description of first aid measures (above) and Indication of immediate medical attention and special treatment needed (below), any additional important symptoms and effects are described in Section 11: Toxicology Information.

Indication of any immediate medical attention and special treatment needed

Notes to physician: No specific antidote. Treatment of exposure should be directed at the control of symptoms and the clinical condition of the patient.

5. FIREFIGHTING MEASURES

Suitable extinguishing media: Water fog or fine spray. Dry chemical fire extinguishers. Carbon dioxide fire extinguishers. Foam. Alcohol resistant foams (ATC type) are preferred. General purpose synthetic foams (including AFFF) or protein foams may function, but will be less effective.

Unsuitable extinguishing media: Do not use direct water stream. May spread fire.

Special hazards arising from the substance or mixture

Hazardous combustion products: During a fire, smoke may contain the original material in addition to combustion products of varying composition which may be toxic and/or irritating. Combustion products may include and are not limited to: Carbon monoxide. Carbon dioxide.

Unusual Fire and Explosion Hazards: Container may rupture from gas generation in a fire situation. Violent steam generation or eruption may occur upon application of direct water stream to hot liquids.

Advice for firefighters

Fire Fighting Procedures: Keep people away. Isolate fire and deny unnecessary entry. Use water spray to cool fire exposed containers and fire affected zone until fire is out and danger of reignition has passed. Fight fire from protected location or safe distance. Consider the use of unmanned hose holders or monitor nozzles. Immediately withdraw all personnel from the area in case of rising sound from venting safety device or discoloration of the container. Burning liquids may be extinguished by dilution with water. Do not use direct water stream. May spread fire. Move container from fire area if this is possible without hazard. Burning liquids may be moved by flushing with water to protect personnel and minimize property damage.

Special protective equipment for firefighters: Wear positive-pressure self-contained breathing apparatus (SCBA) and protective fire fighting clothing (includes fire fighting helmet, coat, trousers, boots, and gloves). If protective equipment is not available or not used, fight fire from a protected location or safe distance.

6. ACCIDENTAL RELEASE MEASURES

Personal precautions, protective equipment and emergency procedures: Keep unnecessary and unprotected personnel from entering the area. Use appropriate safety equipment. For additional information, refer to Section 8, Exposure Controls and Personal Protection.

Environmental precautions: Prevent from entering into soil, ditches, sewers, waterways and/or groundwater. See Section 12, Ecological Information.

Methods and materials for containment and cleaning up: Small spills: Absorb with materials such as: Cat litter. Sawdust. Vermiculite. Zorb-all®. Collect in suitable and properly labeled containers. Large spills: Dike area to contain spill. See Section 13, Disposal Considerations, for additional information.

7. HANDLING AND STORAGE

Precautions for safe handling: Conditions for safe storage: Do not store in: Galvanized steel. Opened or unlabeled containers. Store in the following material(s): Carbon steel. Stainless steel. Store in original unopened container. See Section 10 for more specific information. Additional storage and handling information on this product may be obtained by calling your sales or customer service contact.

8. EXPOSURE CONTROLS/PERSONAL PROTECTION

Control parameters

Exposure limits are listed below, if they exist.

Component	Regulation	Type of listing	Value/Notation
Propylene glycol	US WEEL	TWA	10 mg/m3
	CA ON OEL	TWAEV Total	155 mg/m3 50 ppm
	CA ON OEL	TWAEV	10 mg/m3
	CA ON OEL	TWA	155 mg/m3 50 ppm
	CA ON OEL	TWA	10 mg/m3
	CA ON OEL	TWA Vapour and aerosols	155 mg/m3 50 ppm
	CA ON OEL	TWA aerosol	10 mg/m3

Consult local authorities for recommended exposure limits.

Exposure controls

Engineering controls: Use local exhaust ventilation, or other engineering controls to maintain airborne levels below exposure limit requirements or guidelines. If there are no applicable exposure limit requirements or guidelines, general ventilation should be sufficient for most operations. Local exhaust ventilation may be necessary for some operations.

Individual protection measures

Eye/face protection: Use safety glasses (with side shields).

Skin protection

Hand protection: Use gloves chemically resistant to this material when prolonged or frequently repeated contact could occur. Examples of preferred glove barrier materials include: Butyl rubber. Natural rubber ("latex"). Neoprene. Nitrile/butadiene rubber ("nitrile" or "NBR"). Polyethylene. Ethyl vinyl alcohol laminate ("EVAL"). Polyvinyl alcohol ("PVA"). Polyvinyl chloride ("PVC" or "vinyl"). NOTICE: The selection of a specific glove for a particular application and duration of use in a workplace should also take into account all relevant workplace factors such as, but not limited to: Other chemicals which may be handled, physical requirements (cut/puncture protection, dexterity, thermal protection), potential body reactions to glove materials, as well as the instructions/specifications provided by the glove supplier.

Other protection: Wear clean, body-covering clothing.

Respiratory protection: Respiratory protection should be worn when there is a potential to exceed the exposure limit requirements or guidelines. If there are no applicable exposure limit requirements or guidelines, wear respiratory protection when adverse effects, such as respiratory irritation or discomfort have been experienced, or where indicated by your risk assessment process. In misty atmospheres, use an approved particulate respirator. The following should be effective types of air-purifying respirators: Organic vapor cartridge with a particulate pre-filter.

9. PHYSICAL AND CHEMICAL PROPERTIES

Appearance

Physical state	Liquid.
Color	Yellow to green
Odor	Characteristic
Odor Threshold	No test data available
pH	9.5 50% <i>Literature</i>
Melting point/range	Not applicable to liquids
Freezing point	supercools
Boiling point (760 mmHg)	152 °C <i>Literature</i>
Flash point	closed cup 104 °C <i>Pensky-Martens Closed Cup ASTM D 93</i> Propylene glycol., (based on major component)
Evaporation Rate (Butyl Acetate = 1)	< 0.5 <i>Estimated.</i>
Flammability (solid, gas)	Not applicable to liquids
Lower explosion limit	2.6 % vol <i>Literature</i> Propylene glycol.
Upper explosion limit	12.5 % vol <i>Literature</i> Propylene glycol.

Vapor Pressure	2.2 mmHg <i>Literature</i>
Relative Vapor Density (air = 1)	>1.0 <i>Literature</i>
Relative Density (water = 1)	1.06 at 20 °C / 20 °C <i>Literature</i>
Water solubility	100 % <i>Literature</i>
Partition coefficient: n-octanol/water	No data available
Auto-ignition temperature	371 °C <i>Literature</i> Propylene glycol.
Decomposition temperature	No test data available
Kinematic Viscosity	43.4 cSt at 20 °C <i>Literature</i>
Explosive properties	No data available
Oxidizing properties	No data available
Molecular weight	No data available

NOTE: The physical data presented above are typical values and should not be construed as a specification.

10. STABILITY AND REACTIVITY

Reactivity: No data available

Chemical stability: Stable under recommended storage conditions. See Storage, Section 7. Hygroscopic

Possibility of hazardous reactions: Polymerization will not occur.

Conditions to avoid: Exposure to elevated temperatures can cause product to decompose. Generation of gas during decomposition can cause pressure in closed systems. Avoid direct sunlight or ultraviolet sources.

Incompatible materials: Avoid contact with: Strong acids. Strong bases. Strong oxidizers.

Hazardous decomposition products: Decomposition products depend upon temperature, air supply and the presence of other materials. Decomposition products can include and are not limited to: Aldehydes. Alcohols. Ethers. Organic acids.

11. TOXICOLOGICAL INFORMATION

Toxicological information appears in this section when such data is available.

Acute toxicity

Acute oral toxicity

Very low toxicity if swallowed. Harmful effects not anticipated from swallowing small amounts.

For the major component(s): Propylene glycol.
LD50, Rat, > 20,000 mg/kg

Acute dermal toxicity

Prolonged skin contact is unlikely to result in absorption of harmful amounts.

For the major component(s): Propylene glycol.
LD50, Rabbit, > 20,000 mg/kg

Acute inhalation toxicity

At room temperature, exposure to vapor is minimal due to low volatility. Mist may cause irritation of upper respiratory tract (nose and throat).

For the major component(s):
LC50, Rat, 4 Hour, vapour, 6.15 mg/l No deaths occurred following exposure to a saturated atmosphere.

Skin corrosion/irritation

Prolonged contact is essentially nonirritating to skin.
Repeated contact may cause flaking and softening of skin.

Serious eye damage/eye irritation

May cause slight temporary eye irritation.
Corneal injury is unlikely.

Sensitization

For the major component(s):
Did not cause allergic skin reactions when tested in humans.

For respiratory sensitization:
No relevant data found.

Specific Target Organ Systemic Toxicity (Single Exposure)

Evaluation of available data suggests that this material is not an STOT-SE toxicant.

Specific Target Organ Systemic Toxicity (Repeated Exposure)

In rare cases, repeated excessive exposure to propylene glycol may cause central nervous system effects.

Carcinogenicity

Similar formulations did not cause cancer in laboratory animals.

Teratogenicity

For the major component(s): Did not cause birth defects or any other fetal effects in laboratory animals.

Reproductive toxicity

For the major component(s): In animal studies, did not interfere with reproduction. In animal studies, did not interfere with fertility.

Mutagenicity

In vitro genetic toxicity studies were negative. For the major component(s): Animal genetic toxicity studies were negative.

Aspiration Hazard

Based on physical properties, not likely to be an aspiration hazard.

12. ECOLOGICAL INFORMATION

Ecotoxicological information appears in this section when such data is available.

Toxicity

Propylene glycol

Acute toxicity to fish

Material is practically non-toxic to aquatic organisms on an acute basis (LC50/EC50/EL50/LL50 >100 mg/L in the most sensitive species tested).
LC50, *Oncorhynchus mykiss* (rainbow trout), static test, 96 Hour, 40,613 mg/l, OECD Test Guideline 203

Acute toxicity to aquatic invertebrates

LC50, *Ceriodaphnia dubia* (water flea), static test, 48 Hour, 18,340 mg/l, OECD Test Guideline 202

Acute toxicity to algae/aquatic plants

ErC50, *Pseudokirchneriella subcapitata* (green algae), 96 Hour, Growth rate inhibition, 19,000 mg/l, OECD Test Guideline 201

Toxicity to bacteria

NOEC, *Pseudomonas putida*, 18 Hour, > 20,000 mg/l

Chronic toxicity to aquatic invertebrates

NOEC, *Ceriodaphnia dubia* (water flea), semi-static test, 7 d, number of offspring, 13,020 mg/l

Dipotassium hydrogen phosphate

Acute toxicity to fish

Material is practically non-toxic to aquatic organisms on an acute basis (LC50/EC50/EL50/LL50 >100 mg/L in the most sensitive species tested).
LC50, *Leuciscus idus* (Golden orfe), static test, 48 Hour, > 900 mg/l, Method Not Specified.

Persistence and degradability

Propylene glycol

Biodegradability: Material is readily biodegradable. Passes OECD test(s) for ready biodegradability. Biodegradation may occur under anaerobic conditions (in the absence of oxygen).

10-day Window: Pass

Biodegradation: 81 %

Exposure time: 28 d

Method: OECD Test Guideline 301F or Equivalent

10-day Window: Not applicable

Biodegradation: 96 %

Exposure time: 64 d

Method: OECD Test Guideline 306 or Equivalent

Theoretical Oxygen Demand: 1.68 mg/mg

Chemical Oxygen Demand: 1.53 mg/mg

Biological oxygen demand (BOD)

Incubation Time	BOD
5 d	69.000 %
10 d	70.000 %
20 d	86.000 %

Photodegradation**Atmospheric half-life:** 10 Hour**Method:** Estimated.**Dipotassium hydrogen phosphate****Biodegradability:** Biodegradation is not applicable.**Bioaccumulative potential****Propylene glycol****Bioaccumulation:** Bioconcentration potential is low (BCF < 100 or Log Pow < 3).**Partition coefficient: n-octanol/water(log Pow):** -1.07 Measured**Bioconcentration factor (BCF):** 0.09 Estimated.**Dipotassium hydrogen phosphate****Bioaccumulation:** No bioconcentration is expected because of the relatively high water solubility.**Mobility in soil****Propylene glycol**

Given its very low Henry's constant, volatilization from natural bodies of water or moist soil is not expected to be an important fate process.

Potential for mobility in soil is very high (Koc between 0 and 50).

Partition coefficient (Koc): < 1 Estimated.**Dipotassium hydrogen phosphate**

No relevant data found.

13. DISPOSAL CONSIDERATIONS

Disposal methods: DO NOT DUMP INTO ANY SEWERS, ON THE GROUND, OR INTO ANY BODY OF WATER. All disposal practices must be in compliance with all Federal, State/Provincial and local laws and regulations. Regulations may vary in different locations. Waste characterizations and compliance with applicable laws are the responsibility solely of the waste generator. AS YOUR SUPPLIER, WE HAVE NO CONTROL OVER THE MANAGEMENT PRACTICES OR MANUFACTURING PROCESSES OF PARTIES HANDLING OR USING THIS MATERIAL. THE INFORMATION PRESENTED HERE PERTAINS ONLY TO THE PRODUCT AS SHIPPED IN ITS INTENDED CONDITION AS DESCRIBED IN MSDS SECTION: Composition Information. FOR UNUSED & UNCONTAMINATED PRODUCT, the preferred options include sending to a licensed, permitted: Recycler. Reclaimer. Incinerator or other thermal destruction device.

14. TRANSPORT INFORMATION

TDG

Not regulated for transport

Classification for SEA transport (IMO-IMDG):

Transport in bulk according to Annex I or II of MARPOL 73/78 and the IBC or IGC Code

Not regulated for transport
Consult IMO regulations before transporting ocean bulk

Classification for AIR transport (IATA/ICAO):

Not regulated for transport

This information is not intended to convey all specific regulatory or operational requirements/information relating to this product. Transportation classifications may vary by container volume and may be influenced by regional or country variations in regulations. Additional transportation system information can be obtained through an authorized sales or customer service representative. It is the responsibility of the transporting organization to follow all applicable laws, regulations and rules relating to the transportation of the material.

15. REGULATORY INFORMATION

Canadian Domestic Substances List (DSL)

This product contains at least one substance which is not listed on the Canadian Domestic Substances List (DSL).

16. OTHER INFORMATION

Hazard Rating System

NFPA

Health	Fire	Reactivity
0	1	0

Revision

Identification Number: 101199333 / A208 / Issue Date: 01/19/2017 / Version: 7.0
Most recent revision(s) are noted by the bold, double bars in left-hand margin throughout this document.

Legend

CA ON OEL	Canada, Ontario OELs
-----------	----------------------

TWA	8-hr Time Weighted Average
TWAEV	time-weighted average exposure value
US WEEL	USA. Workplace Environmental Exposure Levels (WEEL)

Information Source and References

This SDS is prepared by Product Regulatory Services and Hazard Communications Groups from information supplied by internal references within our company.

DOW CHEMICAL CANADA ULC urges each customer or recipient of this (M)SDS to study it carefully and consult appropriate expertise, as necessary or appropriate, to become aware of and understand the data contained in this (M)SDS and any hazards associated with the product. The information herein is provided in good faith and believed to be accurate as of the effective date shown above. However, no warranty, express or implied, is given. Regulatory requirements are subject to change and may differ between various locations. It is the buyer's/user's responsibility to ensure that his activities comply with all federal, state, provincial or local laws. The information presented here pertains only to the product as shipped. Since conditions for use of the product are not under the control of the manufacturer, it is the buyer's/user's duty to determine the conditions necessary for the safe use of this product. Due to the proliferation of sources for information such as manufacturer-specific (M)SDSs, we are not and cannot be responsible for (M)SDSs obtained from any source other than ourselves. If you have obtained an (M)SDS from another source or if you are not sure that the (M)SDS you have is current, please contact us for the most current version.

KSLG-20E, KSLG-40E, KSLG-60E, KSLG-80E, and KSLG-100E Gas Kettles



A product with the Southbend Steam name incorporates the best in durability and low maintenance. We all recognize, however, that replacement parts and occasional professional service may be necessary to extend the useful life of this appliance. When service is needed, contact a Southbend Steam Authorized Service Agency, or your dealer. To avoid confusion, always refer to the model number, serial number, and type of your appliance.



SOUTHBEND STEAM

 MIDDLEBY A Middleby Company

1100 Old Honeycutt Road Fuquay-Varina, North Carolina 27526 USA

www.southbendnc.com